



Modular ice maker - Scale system Daily production up to 900 kg

| | |
|---------------|--|
| Hotel | ██ |
| Restaurant | ██ |
| Fast food | ██ |
| Bar | ██ |
| Disco | ██ |
| Fish market | ██ |
| Supermarket | ██ |
| Medical & SPA | ██ |
| Industry | ██ |

► Position n°



► Features & Plus

- Sub-cooled scale ice 99% dry
- 1l (water) - 1kg (ice) - only Air cooled
- AISI 304 SS Scotch Brite finish
- Tropical class +43°C
- Specific volume 1 m³ = 430 kg of ice
- Vertical fixed "no leak" evaporator
- AISI 316L SS evaporator
- Cleanable antiscaling filter
- FDA approved - ABS plastic components
- Easy cleanable internal rounded surfaces
- RoHS Free
- Automatic water charge
- Standard and special voltages



AISI 304 SS
Scotch Brite finish



Vertical fixed "no
leak" evaporator



Cleanable
antiscaling filter

► Usable Bins

- Bin 550V DS
- Double Roller Bin 500
- Double Roller Bin 1200

► Certifications available for this model





Modular ice maker - Scale system
Daily production up to 900 kg

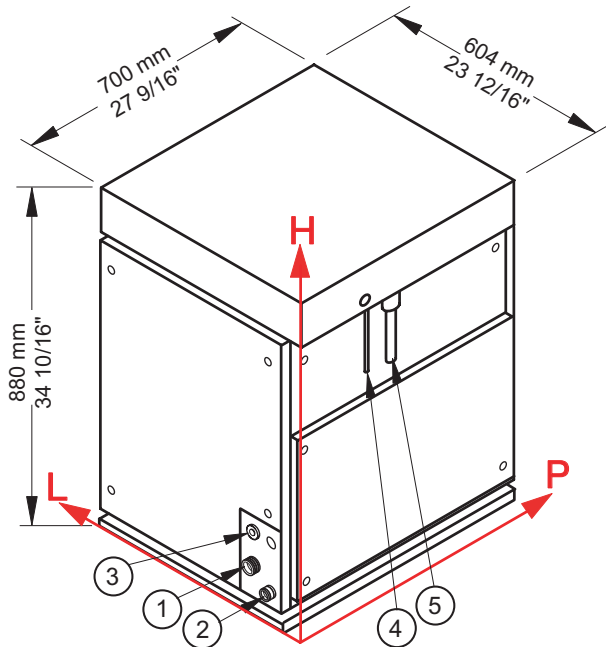

► **Working conditions**

- Location: **Indoor**

| | Min | Max |
|----------------------|-----------------|-----------------|
| Ambient temperature | +10° C / +50° F | +43° C / 110° F |
| Water temperature | +3° C / +37° F | +32° C / +90° F |
| Voltage | -10% | +10% |
| Water inlet pressure | 1bar (14 psi) | 6bar (84 psi) |

► **Connections**

- ① Water inlet
- ② Water outlet
- ③ Electrical connection
- ④ Refrigerant feeding pipe
- ⑤ Outlet pipe of gaseous refrigerant

► **Technical information**

| | |
|---------------------------|--|
| Production in 24h | 900 kg / 1984 lbs |
| Refrigerant | R404A - R507 - R448A - R449A - R407F - R452A |
| Refrigerant capacity | 5000 W (evap. temp. -23° C) |
| Water consumption | 1 l/kg - 12,0 gal/100 lbs |
| Standard voltage | 220-240 V ~ 50 Hz |
| Average power consumption | 180 W |
| Finish | AISI 304 stainless steel, scotch brite |

| | |
|----------------------------|-------------------------------|
| Sizes (L-P-H mm) | 604 - 700 - 880 |
| (L-P-H in) | 23 12/16 - 27 9/16 - 34 10/16 |
| Sizes with pack (L-P-H mm) | 655 - 785 - 1055 |
| (L-P-H in) | 25 13/16 - 30 14/16 - 41 9/16 |
| Net weight | 138 kg / 304 lbs |
| Gross weight | 153 kg / 337 lbs |

All the technical information need to be considered at the following conditions:
Ambient temperature +21° C
Water temperature +15° C
Average power consumption at +43° C (standard voltage)